



# WP 55

- User manual



Translation of original user manual  
Version: 03 - 2025



# TABLE OF CONTENT:

This user manual outlines proper handling procedures to ensure operator safety and maintenance actions to extend the life of the trolley. The operator should read and understand all the information provided below. This user manual should be made available to any user or controller.

1 - THE MANUFACTURER:	4
2 - DESCRIPTION OF THE EQUIPMENT:	4
3 - CE DECLARATION:	5
4A - HANDLE:	6
4B - OPTIONS:	7
5A - SAFETY - RELIABILITY - IP CODE:	7
5B - CLEANING INSTRUCTIONS FOR STEEL TROLLEY:	8
5C - CLEANING INSTRUCTIONS FOR SS TROLLEY:	9
6 - BATTERY CHARGING:	10
7 - UNPACKING AND COMMISSIONING:	11
8 - USE AND SAFETY PRECAUTIONS:	12
9 - SPARE PARTS:	14
10 - ELECTRICAL DIAGRAM - RI:	24
11 - LOAD CHART:	25
12 - RESIDUAL RISKS:	25
13 - MAINTENANCE:	25
14 - SERVICING AND VERIFICATIONS:	26
15- TROUBLESHOOTING:	27
16 - MANUFACTURING QUALITY:	28
17 - ENVIRONNEMENT:	28
18 - MAINTENANCE BOOKLET:	29

## L1 - THE MANUFACTURER:

You have chosen to use a manual-push trolley WP from EDMOLIFT, designed by REGLIFT.



### REGLIFT

ZAC La Belle Etoile 19, rue Saturne  
44119 GRANDCHAMP DES FONTAINES

Tel: +33 (0)2 28 21 73 95

info@reglift.fr - [www.reglift.com](http://www.reglift.com)

Siren: 819 320 086 - RCS Nantes

APE code: 2899 B

Intra-Community VAT number: FR58819320086

## L2 - DESCRIPTION OF THE EQUIPMENT:

The **WP 55** are manual-push lifting trolley, designed to lift and handle loads of various shapes weighing up to **55 kg** for the **WP 55** with a centre of gravity distance of 400 mm from the mast.

The trolley is equipped with 75 mm wheels at the front and 125 mm at the back. The operator pushes the handle to move the trolley.

The toolholder plate is lifted and lowered by means of a toothed belt driven by an electric motor. The plate is lifted and lowered by means of the control button on the handle. On some versions, a remote control will operate the actions of the trolley.

FORKLIFT	WP 55		
Mast	XS	S	M
Overall height (mm)	1290	1530	1940
Weight of the steel trolley (kg)	33	35	37
Weight of the stainless steel trolley (kg)	44	46	48
Maximum load (kg)*	55		
IP protection	IP 44 / IP 65		
Holding capacity of the belt (kg)	417		
Breaking load of the belt (kg)	1615		
Noise level	Lower than 70 dB		
Resistance to vibration	Lower than 2.5 m/s <sup>2</sup>		
Electrical class	Class 2		

\* Refer to load chart page 25

### **L3 - CE DECLARATION:**



## **Declaration of conformity** pertaining to Machinery Directive **2006 / 42 / CE**

Machine manufacturer:

### **REGLIFT**

ZAC La Belle Etoile - 19, rue Saturne  
44119 Grandchamp des Fontaines  
Tel.: +33 2 28 21 73 95

Machine description: **Manual-push trolley**

Type of product: **WP 55: XS / S / M**

Directive: **2014/35/UE +2014/30/UE**

We hereby confirm that the above-mentioned product has been manufactured in accordance with the requirements of the above-mentioned standards and norms, and in compliance with the requirements of Directive 2006/42/EC + additives, and with EU control standards.

Provision of the technical file:

Reglift - ZAC la Belle Etoile, 19 rue Saturne - 44119 Grandchamp des Fontaines

Grandchamp des Fontaines on: 01-01-2023

Signature:

Frédéric BELAMY - Managing Director of Reglift

A handwritten signature in black ink, appearing to be 'Frédéric Belamy', written over a horizontal line.

## SPECIFIC TERMS:

- 1 • Mast** - Folded steel plate used as a guide rail for the mobile toolholder plate.
- 2 • Structure** - Mechanically-welded assembly that acts as a link between the straddle legs and the mast and contains all the electro-mechanical and energy-related parts.
- 3 • Toolholder plate** - Assembly that can slide into the mast, and is driven by a toothed belt and gear motor. The tool is to be mounted on this assembly.
- 4 • Legs** - Mechanically-welded assembly with four castors ensuring optimum ground stability of the trolley.
- 5 • Ergo Control handle** - Mechanically-welded assembly that acts as the interface between the operator and the trolley, and contains all the controls for operating the trolley.

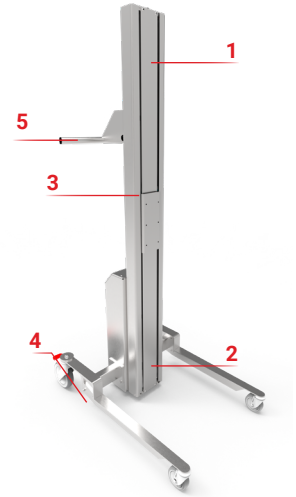

## 4A - HANDLE:

The control panel of the trolley consist of 3 elements:

- 1. The switch: switches on and off the power supply to the trolley.
- 2. Battery charge indicator:

 **Red**  
The battery has to be charged

- 3. Button for operating the trolley. The button must be pressed and held to trigger the action.

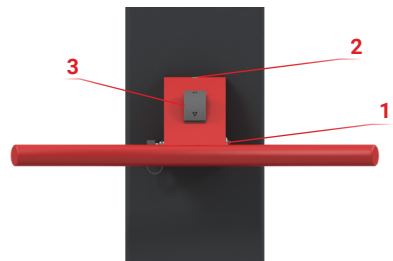

## **L 4B - OPTIONS:**

Find all our available options via this link:

<https://www.reglift.com/en/options/>

There you will find the full description as well as a detailed explanation of the available options for each trolley model: EWA, constant level, position encoder...

## **L 5A - SAFETY - RELIABILITY - IP CODE:**

### **SAFETY SYSTEMS - RELIABILITY:**

The trolley is equipped with several safety systems:

- The electronic board has a feature that prevents the tool from going up when the trolley is overloaded.
- An overrunning clutch device that prevents crushing when the tool is being lowered.

# 5B - CLEANING INSTRUCTIONS FOR STEEL TROLLEY:

## IP RATING:

### Protection against solid object

- Protection from solid particles that are over 1mm in size.
- Most wires, fine screws, large ants, etc.



### Protection against liquids

- From liquids that are every sprayed or splashed from all directions at a low level of force.
- Ingress of moisture is allowed if proven to be harmless ie. water allowed to drip out of the product without compromise.

## SPECIAL INSTRUCTIONS/CAUTIONS

- Always wear proper safety equipment.
- Lower the lifting tool so you don't risk injuring your head when cleaning.
- The battery charger must be unplugged from the mains and the trolley during the cleaning.
- The charging connector must be properly closed with its plastic cap rubber.
- For versions with remote control, the remote control must remain connected to its plug and cleaned exclusively by the use of a wet wipe.

## APPLICATION OF DETERGENT

- ✓ Use a standard cleaning detergent with a neutral pH.
- ✗ Do not use acidic, alkaline or harsh chemicals, which could:
  - damage the drive belt and other sensitive components
  - leave marks on surfaces

## WORK PROCESS

- ✓ Exterior surfaces can be cleaned with a wet cloth.
- ✗ Do not use liquid to clean the trolley, as this will degrade the whole thing electrical and mechanical components.

## KEY INSPECTION POINTS

- ✓ Check that all controls are working properly before handing over the trolley in operation.

# L5C - CLEANING INSTRUCTIONS FOR SS TROLLEY:

## IP RATING:

### Protection against solid object

- Protection against ingress of dust (dust-tight).
- Complete protection against accidental contact.



### Protection against liquids

- IP65 devices are protected against water jets from any angle, but DO NOT submerge in water.

## SPECIAL INSTRUCTIONS/CAUTIONS

- Always wear proper safety equipment.
- Lower the lifting tool so you don't risk injuring your head when cleaning.
- The battery charger must be unplugged from the mains and the trolley during the cleaning.
- The charging connector must be properly closed with its plastic cap rubber.
- For versions with remote control, the remote control must remain connected to its plug and cleaned exclusively by the use of a wet wipe.

## APPLICATION OF DETERGENT



Use a standard cleaning detergent with a neutral pH.



- Do not use acidic, alkaline or harsh chemicals, which could:
- damage the drive belt and other sensitive components
  - leave marks on surfaces

## WORK PROCESS



Exterior surfaces can be cleaned with:

- a wet cloth,
- a standard garden hose.
- a jet cleaner with a maximum permissible pressure of 100 kPa, at a distance of 3m. The trolley must dry for 2 hours after cleaning and before use.



Do not use a pressure greater than 100 kPa, at a distance of 3m.

## KEY INSPECTION POINTS



1. Make sure the trolley is completely dry before next use.
2. Check that all controls are working correctly before putting the trolley back into service.

## 6 - BATTERY CHARGING:

### General information:

When used occasionally or intensively, the trolley should be recharged **at least once or twice a week**, as a complete discharge of the battery may damage it. When storing unused batteries, recharge them **once every 6 months**.

Batteries should always be charged in a room at room temperature. Lithium-ion batteries can be stored in an environment of -20°C, but they will have less autonomy.

### Description of use:

The battery must be fully charged at all times to avoid reducing the battery life of the trolley. When the batteries are being charged, the indicator is red and turns green when the batteries are fully charged.



Green LED



Red LED

- The battery charge indicator on the trolley displays the battery charge level.
- The 24V battery charger is independent and external.

#### Your trolley has a remote control

When charging the batteries, set the trolley on OFF / circuit breaker on.

#### Your trolley has a control handle

Set the circuit breaker to "zero" before charging the trolley.

### Charging procedure:

- Remove the protective cap from the connector of the trolley, then plug the charger in the connector.
- Plug the power cable of the charger in the 220 V socket.

Electrical class: **Class 2**

The batteries and battery charger should only be replaced with REGLIFT-approved equipment.

INFORMATION	LEAD-ACID BATTERY	LITHIUM-ION BATTERY
Type of battery:	Lead-acid - AGM	Lithium-ion - NMC
Power:	9 A	9 A
Quantity required:	2	1
Charger:	230 V - 50-60Hz	230 V - 50-60Hz
Charging time:	7.50 h for 100%	3.50 h for 100%
Lifespan:	150 to 250 cycles	250 to 350 cycles
Weight:	4.85 Kg	1.164 Kg
Maintenance agreed with the manufacturer:	Schedule replacement every 2 years	Schedule replacement every 3 years
REGLIFT reference:	REG-110096	REG-110063



**NEVER USE THE EQUIPMENT WHILE THE BATTERIES ARE BEING CHARGED.**

## 7 - UNPACKING AND COMMISSIONING:

The trolley is delivered with its charger secured on a standard European pallet. It can be handled using a suitable tool (pallet truck, stacker, etc.) and must be stored in a dry place between 0°C and 35°C. Its subsequent handling must be done under the same conditions.

### UNPACKING:

- 1 · Do not use a cutter.
- 2 · Remove the protective plastic film from the bottom.
- 3 · Unscrew the support brackets.
- 4 · Check that the brakes are correctly engaged.
- 5 · Tilt the trolley backwards using the Ergo Control handle and lower it from the pallet.
- 6 · Depending on the weight of the trolley and the tool: it may be necessary to involve more than one person, or to use a jib crane by placing a strap around the handle.

### COMMISSIONING:

The trolley is delivered ready to use.

Before using the trolley for the first time, it is necessary to fully charge the batteries and perform a no-load test.

When switching off the trolley, place the plate with the accessory in the lower position. The user should be informed of their company's internal regulations (compulsory equipment and behaviour) before using this equipment.

The manufacturer disclaims all liability for the consequences resulting from disassembly of the equipment, alterations made beyond the manufacturer's control or use outside of the recommended guidelines.

#### ➤ Assembly of gripping tools:

- Position the tool so that the tool support plate is aligned with the toolholder plate of the trolley.
- Insert the CHC screws M6x16 (4, 6 or 8 screws).
- Torque the screws.

#### ➤ Disassembly of gripping tools:

- Unscrew all the screws.
- Remove the screws, ending with the highest screws.
- Remove the last screw while supporting the gripping tool. Be careful, the latter may be heavy.

The gripping tools can be changed in just a few seconds by a single person using a quick-change kit. In this case, a trolley can be used with several different handling tools, in compliance with the load charts.

## 8 - USE AND SAFETY PRECAUTIONS:

### USE:

The operator pushes the trolley manually using the Ergo Control handle.

The toolholder plate is lifted and lowered by means of the central button on the console or on the remote control. Press and hold the button up to lift and down to lower. The lifting and lowering speed of the plate with the tool is progressive.

Secure the trolley using the wheel brakes when performing lifting or maintenance operations.

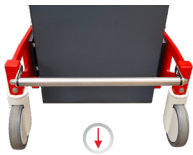

**Low:**  
The wheels are at standstill.

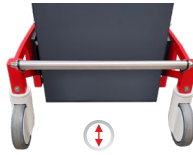

**Middle:**  
The wheels are unlocked.

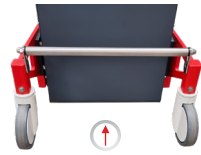

**High:**  
Both wheels are locked in a straight position.

### SAFETY:

Users operating the trolley should receive training as per article R 4323-55 of the French Labour Code.

Using the trolley and its gripping tools requires the use of safety shoes.

Additional PPE depending on the nature of the loads and on in-house company rules for using the trolley.



- Ensure that the user to whom you entrust this equipment has read the user manual and is able to comply with the safety requirements involved in its use.
- The trolley should not be used to lift people.

- Maintain a safe distance from any other person in the working environment.
- Protect the equipment from any uncontrolled intervention when it is not in use.
- No people lifting.
- For indoor use only, in a dry, well-ventilated area away from direct sunlight.
- Never use the equipment while the batteries are charging.
- The load of the trolley should never in any case exceed the corresponding load indicated on the load chart, whether in a fixed position or when lifted.
- Ensure that no one or any part of the body is under the load.
- The load should be evenly distributed and must not exceed the maximum value indicated on the tool.
- The trolley should not be operated on a slope or on soft ground.
- Ensure that the castors are locked before lifting or lowering and when loading or unloading.
- When loaded, the trolley should be handled slowly and in the lower position.
- Never leave the gripping tool at head level.
- Avoid handling a load at the end of the tool and maintain the centre of gravity as specified in the load chart.
- Do not use the equipment for any purpose for which it was not designed.
- The operating area should be free of any obstacle that could cause the trolley to become unbalanced or even tip over.
- Never swing the load.
- The maximum permissible slope is 5% when loaded and 15% when not loaded.

# 9 - SPARE PARTS:

## OVERVIEW:

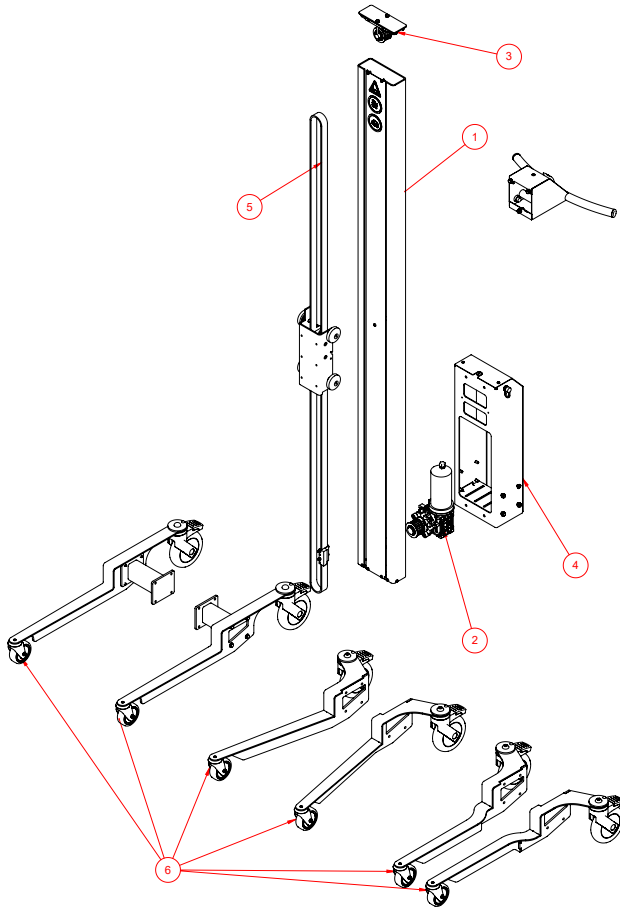

NO	DESCRIPTION	PAGE
1	MAST	15
2	MOTOR	17
3	TOP COVER	18
4	STRUCTURE	19
5	MOBILE LIFT	21
6	BASE	22

# MAST:

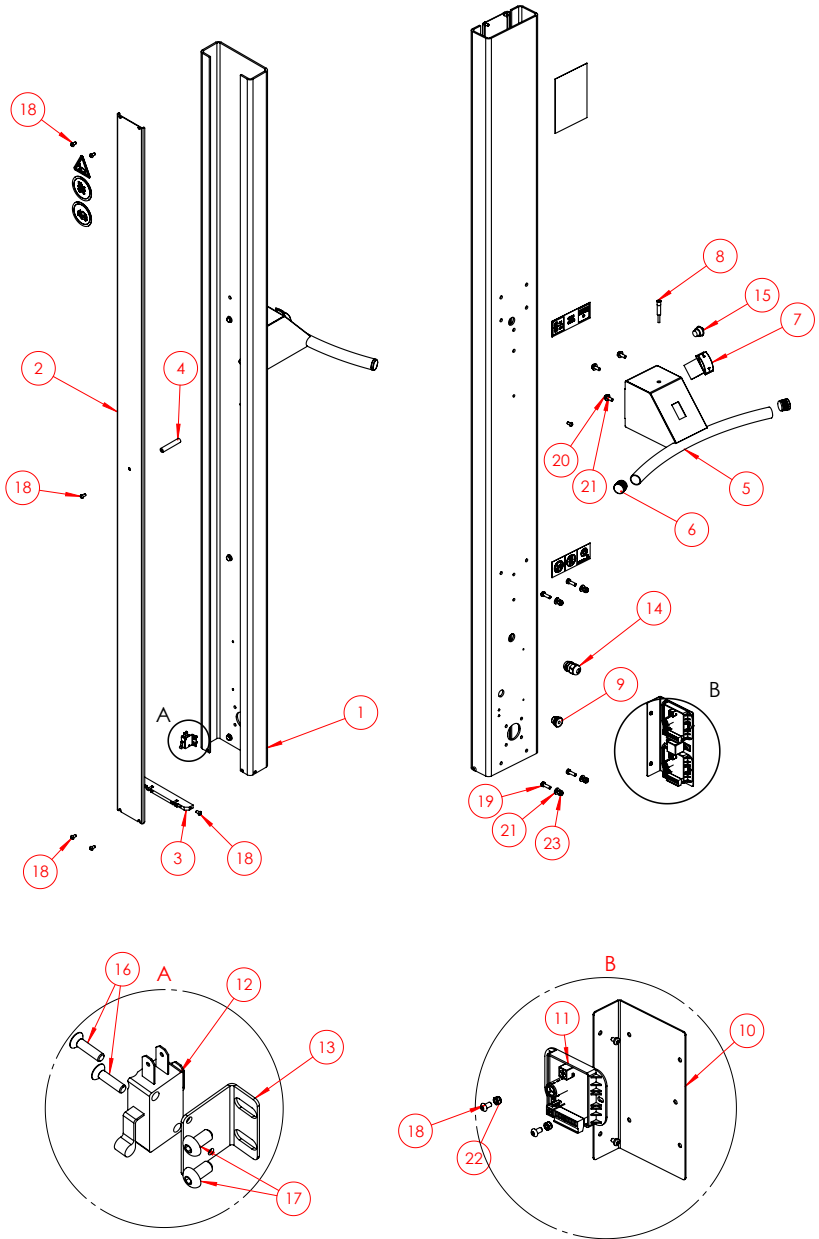

N°	STEEL ITEM NO.	STAINLES STEEL ITEM NO.	DESCRIPTION	QTY
1	REG-100389-A-9006	REG-100407-A	MAST XS	1
	REG-100383-A-9006	REG-100403-A	MAST S	
	REG-100375-A-9006	REG-100401-A	MAST M	
2	REG-100390-A-9006	REG-100408-A	MAST COVER XS	1
	REG-100384-A-9006	REG-100404-A	MAST COVER S	
	REG-100003-A-9006	REG-100009-A	MAST COVER M	
3	REG-100016-A		LOWER STOP	1
4	REG-100020-A		MAST COVER SPACER	1
5	REG-100253-A-7024	REG-100409-A	HANDLE	1
6	REG-110046		TUBE END	2
7	REG-110048		UP/DOWN SWITCH	1
8	REG-110049		CHARGE INDICATOR	1
9	REG-110015		GROMMET	1
10	REG-100024-A		SUPPORT PLATE	1
11	REG-110052		CONTROL CARD	1
12	REG-110028		SENSOR	1
13	REG-100022-A		SENSOR SUPPORT BRACKET	1
14	REG-110016		CABLE-GLAND	1
15	REG-110050		CIRCUIT CUTTER	1
16	FHC M3x12		SCREW	2
17	TORX M4x6		SCREW	2
18	BHC M5x10		SCREW	3
19	TH M6x20		SCREW	3
20	TH M6x16		SCREW	4
21	M6		CONTACT WASHER	3
22	M5		NUT	3
23	M6		NUT	4

# MOTOR:

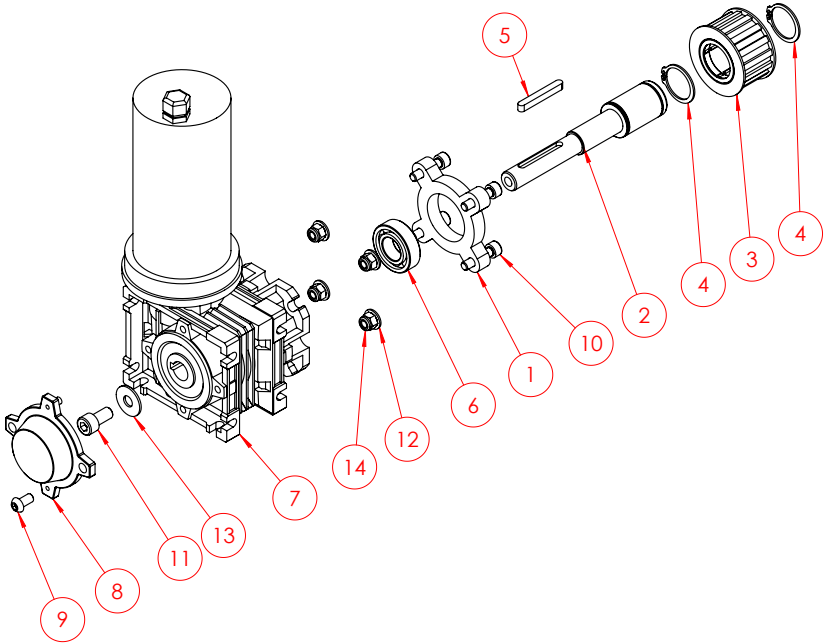

N°	STEEL ITEM NO.	STAINLESS STEEL ITEM NO.	DESCRIPTION	QTY
1	REG-100017-A		ANTIFRICTION BEARING	1
2	REG-100018-A		GEAR MOTOR SHAFT	1
3	REG-120237-A		PULLEY	1
4	REG-110006		CIRCLIPS	2
5	REG-110005		KEY	1
6	REG-110001	REG-110026	BEARING	1
7	REG-110007	REG-110047	GEAR MOTOR	1
8	REG-110008		COVER	1
9	BHC M6x12		SCREW	2
10	CHC M6x25		SCREW	4
11	CHC M8x16		SCREW	1
12	M6		CONTACT WASHER	4
13	L8		WASHER	1
14	M6		NUT	4

## TOP COVER:

**REMINDER :  
WHEN REMOVING  
THE TWO SCREWS ON  
THE TOP OF THE MAST  
COVER, REMEMBER  
TO SECURE THE TOOL.**

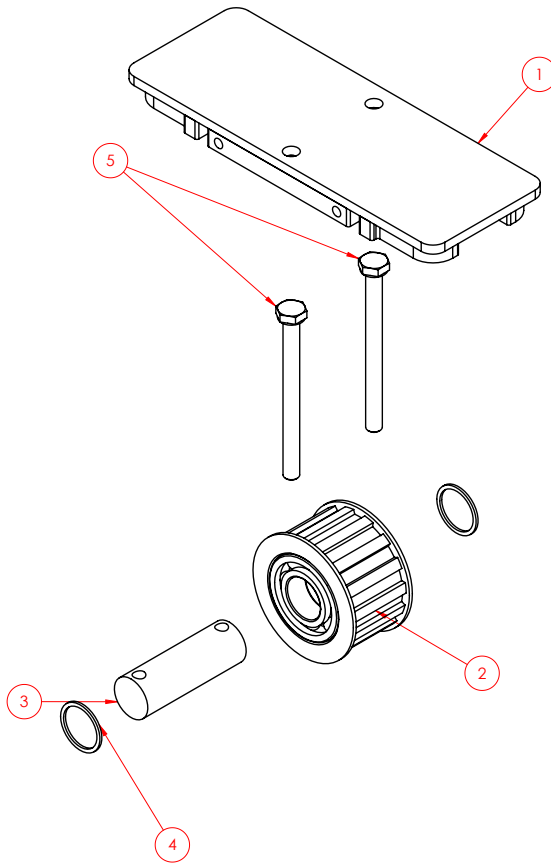

N°	STEEL ITEM NO.	STAINLES STEEL ITEM NO.	DESCRIPTION	QTY
1	REG-100014-A		TOP COVER	1
2	REG-120332-A	REG-120338-A	TENSIONER PULLEY	1
3	REG-100021-A		PULLEY AXLE	1
4	REG-110002		WASHER	2
5	TH M6x70		SCREW	2

# STRUCTURE:

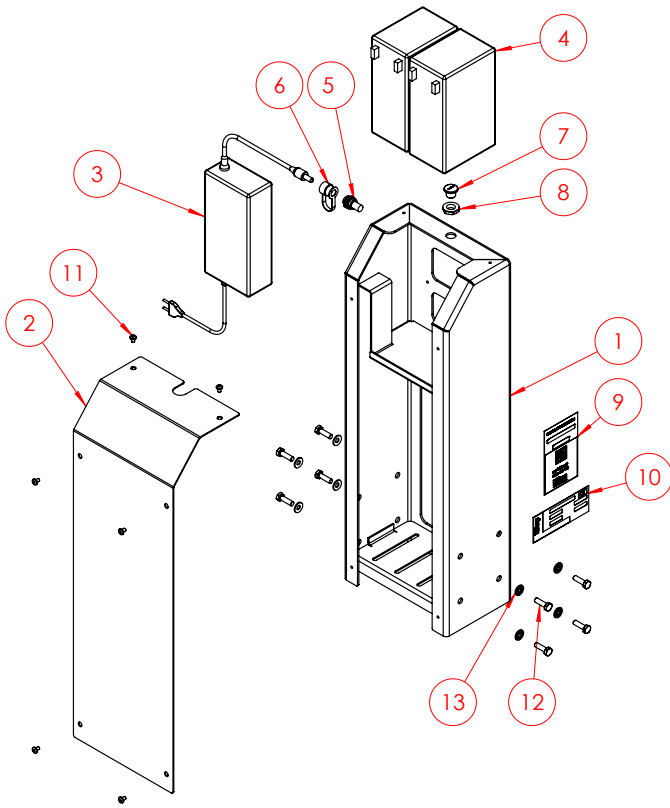

N°	STEEL ITEM NO.	STAINLES STEEL ITEM NO.	DESCRIPTION	QTY
1	REG-100371-A-7024	REG-100397-A	STRUCTURE	1
2	REG-100368-A-7024	REG-100394-A	CASING	1
3	REG-130006		AGM BATTERY CHARGER (AU)	1
	REG-130007		AGM BATTERY CHARGER (UK)	1
	REG-130008		AGM BATTERY CHARGER (US)	1
	REG-130002		AGM BATTERY CHARGER (EU)	1
4	REG-110096		AGM BATTERY	2
5	REG-110064		CHARGING CONNECTOR	1
6	REG-110065		CAP	1
7	REG-110072		OPTOR CAP	1
8	REG-110073		CABLE-GLAND	1
9	REG-110134		PLATE	1
10	REG-110132		PLATE	1
11	TORX M4x6		SCREW	6
12	TH M6x20		NUT	8
13	M6		WASHER	8

# MOBILE LIFT:

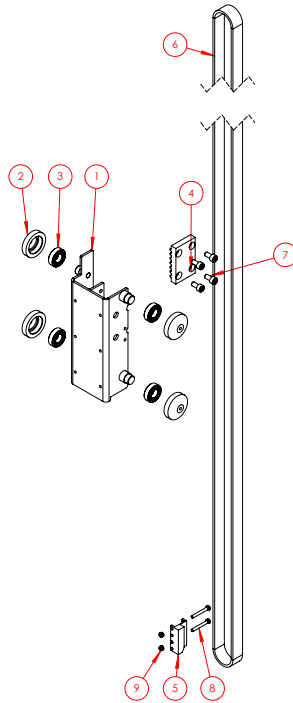

N°	STEEL ITEM NO.	STAINLES, STEEL ITEM NO.	DESCRIPTION	QTY
1	REG-100013-A-7024	REG-100046-A	TROLLEY	1
2	REG-100047-A	REG-100304-A	ROLLER	4
3	REG-110001	REG-110026	BEARING	4
4	REG-110048-A		CONNECTING PLATE	1
5	REG-100049-A		CAM	1
6	REG-110150		BELT	2,29
			BELT	2.87
			BELT	3.7
7	CHC M8x16		SCREW	4
8	TH M5x40		SCREW	2
9	M5		NUT	2

BASE:

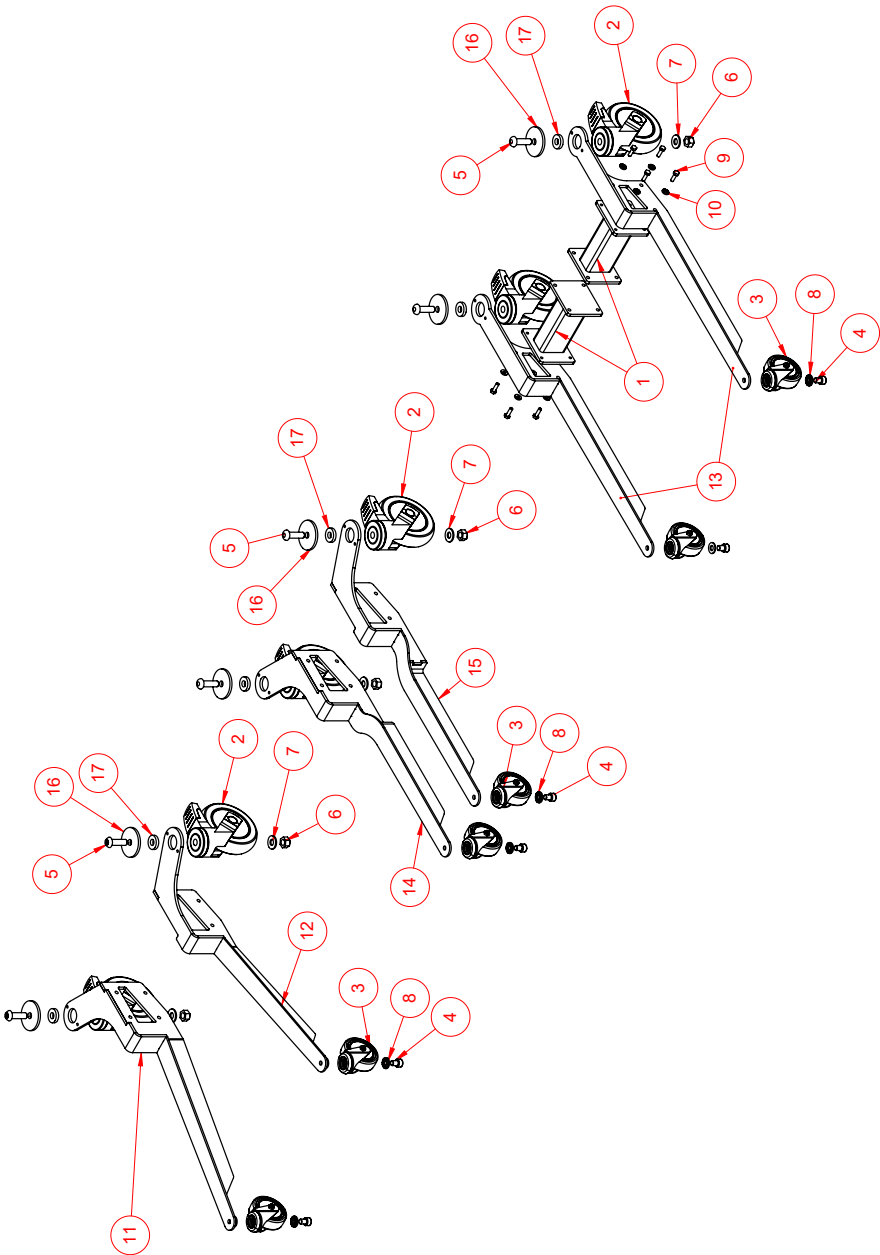

N°	STEEL ITEM NO.	STAINLES STEEL ITEM NO.	DESCRIPTION	QTY
1	REG-100013-A	REG-100399-A	SPACER	2
2	REG-110054		WHEEL	2
3	REG-110198		CASTOR	2
4	CHC M10x25		SCREW	2
5	BHC M12x40		SCREW	2
6	M12		NUT	2
7	M12		WASHER	2
8	M10		WASHER	2
9	TH M6x20		SCREW	8
10	M6		WASHER	8
11	REG-100370-A-7024	REG-100396-A	ANGLE BASE R	1
12	REG-100369-A-7024	REG-100395-A	ANGLE BASE L	1
13	REG-100372-A-7024	REG-100398-A	BASE 500	2
14	REG-100386-A-7024	REG-100405-A	CENTRAL BASE R	1
15	REG-100385-A-7024	REG-100406-A	CENTRAL BASE L	1
16	REG-100026-A-7024	REG-100027-A	WASHER	2
17	REG-100011-A		WASHER	2

# 10 - ELECTRICAL DIAGRAM - R55:

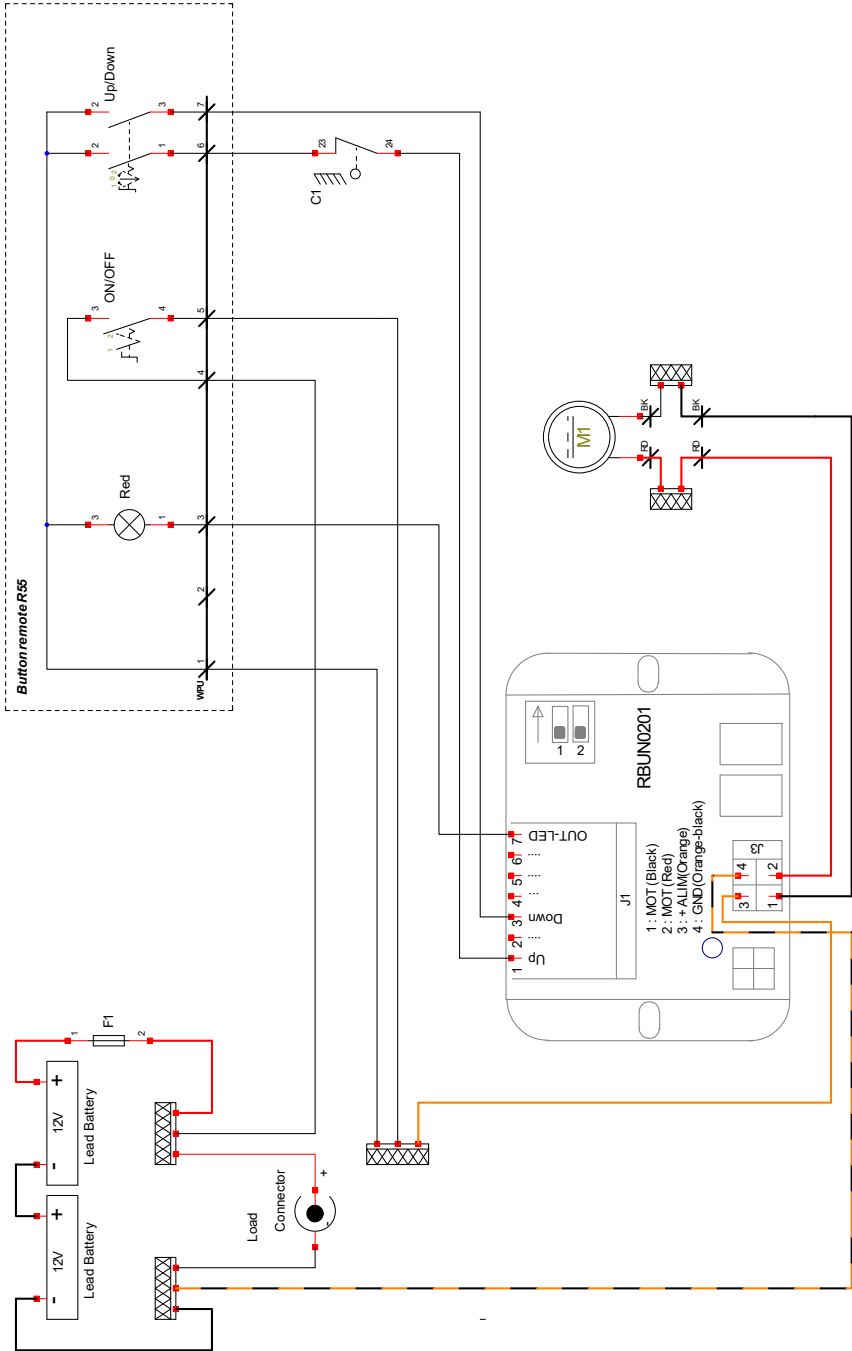

## L11 - LOAD CHART:

The **WP 55** type **XS**, type **S** and type **M** are operator-operated manual-push trolleys. Designed to lift and handle loads of various shapes weighing up to 65 kg at a distance of 400 mm from the mast.

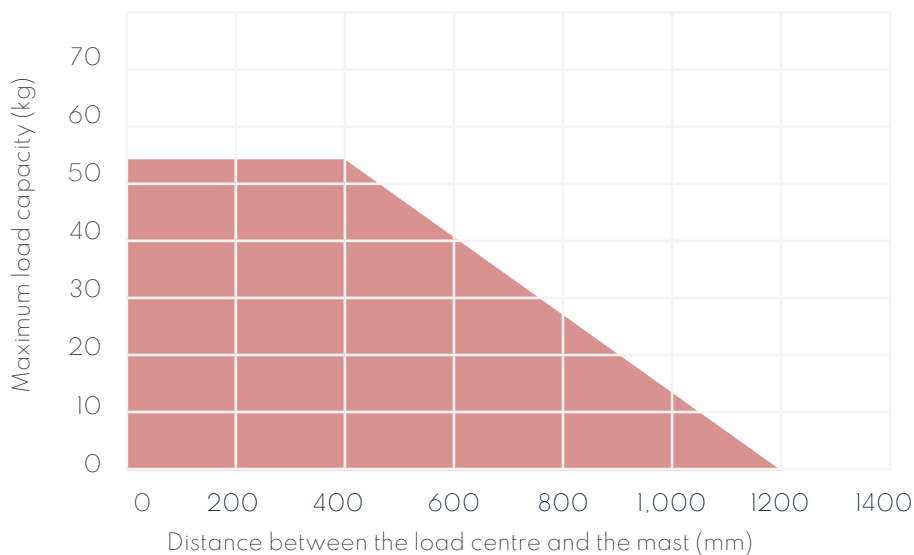

## L12 - RESIDUAL RISKS:

Never stand under the trolley tool.

Always disconnect the batteries from the trolley before performing maintenance.

Screw all parts of the trolley back to reduce noise and vibration.

For any intervention on the internal components of the mast (tool toolholder lift, belt, limit switches, etc.) place the gripping tool in the lower position.

## L13 - MAINTENANCE:

Important informations on how to replace the different parts of the trolley:

### > BY THE CUSTOMER:

Possibility of intervention by the customer on request of the technical documentation to REGLIFT or one of its dealers:

- Battery
- Wheel

## ➤ BY A REGLIFT CERTIFIED TECHNICIAN:

Contact REGLIFT or one of his autorised distributors for any maintenance or replacement on the following parts:

- Belt
- Motor
- Relay box
- Control buttons
- Replacing straddle legs
- Micro switch
- Disengageable pulley

## ➤ **Important:** Do not alter or add any component to the trolley without the manufacturer's approval.

(Refer to the warranty certificate which voids the warranty for any alteration or replacement of parts and supplies that do not comply with manufacturer recommendations).

## L 14 - SERVICING AND VERIFICATIONS:

Le trolley is subject to a commissioning check and a periodic check every **6 months**.

If the equipment is in a potentially dangerous state of disrepair, the user should disable the equipment.

### EVERY 6 MONTHS:

- Unscrew the 5 screws of the mast cover and check that the belt does not come out of the pulley and that it is in good visual condition.
- Check the tightness of the screws.
- Check the batteries (deformations, overheating)

### EVERY YEAR:

- Check the mechanical part (toothed belt, toolholder plate, castors, structure, handle and safety devices, etc.)
- Check the electrical part (circuit breaker, contactor, control, batteries, motors, coils, chargers, etc.)

## EVERY 5 YEARS:

- Change the transmission system
  - Toothed pulley
  - Overrunning clutch
  - Flat pulley
  - Motor shaft

## 15- TROUBLESHOOTING:

ISSUES	CHECKPOINTS	REPAIRS
The belt deviates to the right or left on the tensioner pulley and jumps teeth on the toothed pulley of the gear motor	Belt positioning	First check that the tensioner pulley is aligned with the mast and then tighten one of the 2 tensioner pulley screws by a quarter turn until the belt is centred on the tensioner - go back and forth several times to check this alignment
The belt jumps teeth on the toothed pulley of the gear motor	Belt tension	Check the belt tension using a torque wrench, for WP 55/65/85 torque to 1.5N/m, for WP 125 torque to 2N/m, for WP 205 torque to 2.5N/m and for WP 285 torque to 2N/m
The belt is noisy	Is it damaged? Has any foreign object penetrated between the belt and the motor pulley?	Change the belt
	Check the fuse	Change the fuse
	Check the up / down control button	Change the switch
	Check the overrunning clutch	Change the overrunning clutch with the toothed pulley of the gear motor
The mobile lift no longer lifts	Check the gear motor	Change the gear motor
	Check the load	The load should not exceed the SWL of the trolley
	Check the circuit breaker is 'ON'	Change the circuit breaker or check the electrical wiring
	Check the condition of the electronic board	Reinstall the programme or change the electronic board
The mobile lift lifts with difficulty when loaded	Check the condition of the battery	Recharge the batteries
	Check the battery voltage	Change the batteries
The trolley moves with difficulty	Check the condition of the castors	Change the castors
The trolley no longer charges	Check the condition of the batteries	Change the batteries
	Check the charger, the LED turns green when it is charged	Change the charger

## **L16 - MANUFACTURING QUALITY:**

To ensure the quality of our forklifts when they leave the factory, we carry out a series of tests on each range of forklifts. They are tested on a test bench under "normal" conditions (1 up and down cycle every 2 minutes until the batteries are discharged) and are then subjected to an overload test (the trolley must withstand a load of at least 1.25 times its maximum load for a period of 1 hour).

For each trolley assembled, we carry out several series of up/down cycles at 1.10 dynamic and 1.25 static times the maximum load to validate the mechanics of each trolley before shipment.

## **L17 - ENVIRONNEMENT:**

In our efforts to reduce the carbon footprint generated by the production of the trolleys, as well as prioritising France-based manufacturing, we have selected suppliers located close to our production centre.



**MADE IN  
FRANCE**



---

When replacing one or more parts of the trolley, remember to recycle them by dropping them off at a collection centre.

## 18 - MAINTENANCE BOOKLET:

- Maintenance booklet: as per French ministerial order of 2 March 2004
- Commissioning checks: the reference article is amended to R4323-22 (replacing R233.11.1)
- Re-commissioning checks: the reference article is amended to R4323-28 (replacing R233.11.2)
- Periodic general checks: the reference articles are amended to R4323-22 to R4323-28, R4721-11 and R4535-7 (replacing R233.11)

The trolley is subject to a commissioning check and a periodic check every 6 months as per French ministerial order of 1 March 2004.

The term "lifting equipment" refers to devices, including those operated by direct human power, and their tools, operated by one or more operators, one of the functions of which is to move a load or persons with significant height variation during the process, the load not being permanently connected to the equipment.

**THE MAINTENANCE LOGBOOK IS MADE AVAILABLE TO THE HEALTH AND SAFETY INSPECTOR, TO OFFICIALS FROM THE FRENCH REGIONAL HEALTH INSURANCE SERVICES, TO THE HEALTH, SAFETY AND WORKING CONDITIONS COMMITTEE AND TO STAFF REPRESENTATIVES.**

It is also made available to those responsible for carrying out regulatory checks on the equipment during commissioning or re-commissioning as well as for carrying out periodic checks.

Type of maintenance operations specified by the manufacturer:

- Check • Inspection • Repair • Replacement • Alteration

DATE OF TASK	REFERENCE REPLACED	NATURE OF THE TASK	NAME OF THE OPERATOR	SIGNATURE OF THE OPERATOR





